

Heavy Duty / Propylene

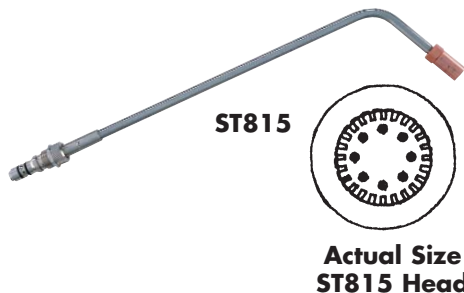

ST815 - Medium capacity tip:
Use in WH200 &
SW1B handles.

Torch Head Stock No. 4642

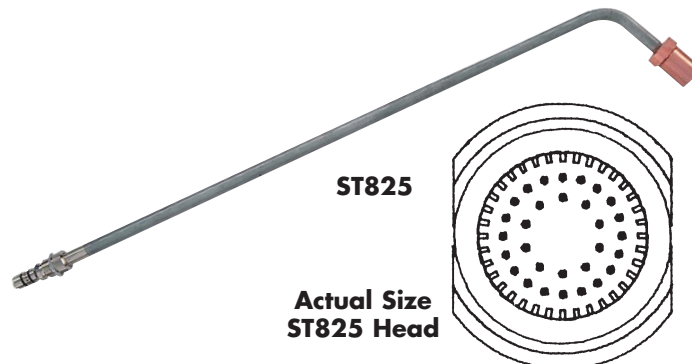

ST825 - High capacity heating tip:
Use in WH200 & SW1B torch handles
with 3/8" (10mm) I.D. hoses.

Torch Head Stock No. 4639

Stock No.	No. of Flames	Uses	Pressures (PSIG)		Consumption (SCFH)		Average BTU	**Fuel Cylinders Required	Overall Length
			Oxygen	Fuel Gas	Oxygen	Fuel Gas			
ST815	Fluted	Propylene	37-77	13-37	390-655	120-235	415,000	1-2	20-1/2" (521mm)
ST825			60-110	20-35	580-1500	225-525	830,000	2-5	31" (787mm)

****Note:** Continuous use with 105 lb. propylene cylinders @ 70° F.

Medium Duty / Propylene

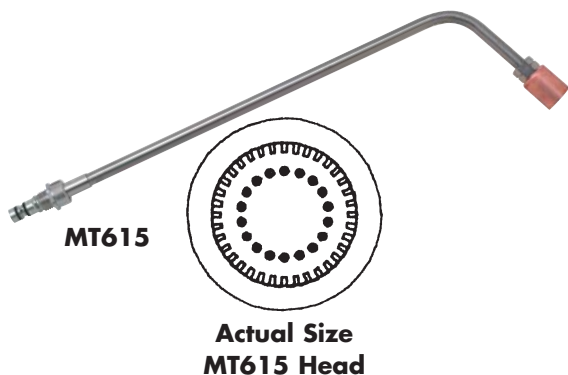

MT615 & MT810 - Medium capacity tip: Use in WH100, MW5A & CW5A torch handles.

MT615 Torch Head Stock No. 1495

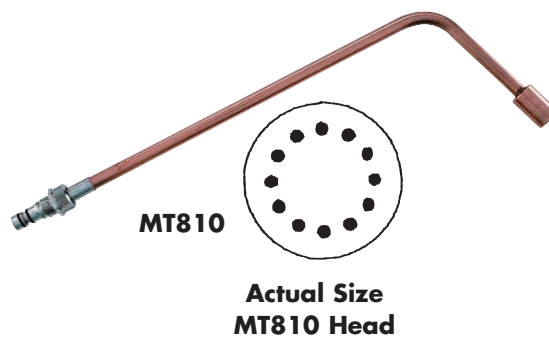

Stock No.	No. of Flames	Uses	Pressures (PSIG)		Consumption (SCFH)		Average BTU	**Fuel Cylinders Required	Overall Length
			Oxygen	Fuel Gas	Oxygen	Fuel Gas			
MT615	Fluted	Propylene	20-60	10-25	235-430	100-160	280,000	2	19" (483mm)
MT810	12		10-22	10-20	120-160	42-58	115,000	1	18" (457mm)

****Note:** Continuous use with 105 lb. propylene cylinders @ 70° F.

CAUTION: Heating tips must be used in conjunction with high flow flashback arrestors. It may be necessary to increase outlet pressures to compensate for flow restrictions that may be created by flashback arrestors.

Tips