

Heavy Duty/Medium Duty

Heavy Duty Cutting Attachments

Torches

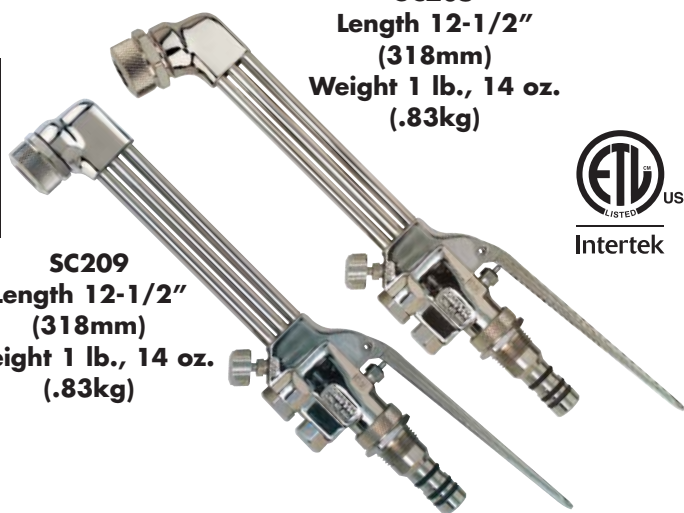

SC205
Length 12-1/2"
(318mm)
Weight 1 lb., 14 oz.
(.83kg)

SC209
Length 12-1/2"
(318mm)
Weight 1 lb., 14 oz.
(.83kg)



SC205 & SC209

Cuts up to 8" (203mm) thick steel. Solid silver brazed construction. Features "O" ring seating and easy-to-change slip-in Graf-Tite® cutting tips with cost saving soft-seats. Covered by the "LIFETIME" WARRANTY & Service Agreement. Use with any industrial equal pressure fuel gases — acetylene, propane, natural gas, propylene, hydrogen, MAPP®, and many others. Several models of standard and special purpose tips are available for use in SC200 Series Cutting Assemblies.

SEE PAGES 32 - 37 FOR CUTTING TIPS

USED WITH: Torch Handles - SW1, SW1A & SW1B & WH200. DG200 Series Valve Assembly Replacement 13936 (also for SC Series)

Medium Duty Cutting Attachment

Popular medium duty cutting attachment easily cuts up to 6" (153mm) steel. Solid construction to last a lifetime - silver brazed joints, stainless steel tubes, brass forged butt and head. Has the same quality features and construction as the larger and heavier Smith cutting attachments.

Use with any industrial medium pressure fuel gases - acetylene, propane, butane, natural gas, propylene, HPG®, MAPP®, hydrogen and many others. MC505 & MC509 Covered by "LIFETIME" WARRANTY & Service Agreements.

USED WITH: Torch Handles - MW5, MW5A WH100 & CW5A.

SEE PAGES 38-39 FOR CUTTING TIPS

100% TESTED & MADE IN THE USA



MC505
Length 11-1/4"
(286mm)
Weight 1 lb. 2 oz.
(.50kg)

MC509
Length 11-1/4" (286mm)
Weight 1 lb. 2 oz. (.50kg)



CC509P
3-Year
Limited
Warranty

16229
Adjustable Circle
Cutting Guide
Cutting range from
5/8" - 12" holes



Works with all
cutting assemblies

Stock No.	Style	Head Angle	For Use With Tips:
SC205	Heavy Duty	75°	Oxygen/Acetylene: SC12-00 thru SC12-5, SC56-1 thru SC56-5, Oxygen/Propane, Oxygen/Propane Based: SC40-0 thru SC40-5, SC46-2 thru SC46-5, SC50-1 thru SC50-5, SC2-2, SC2-4,
SC209	Heavy Duty	90°	Oxygen/Propylene: SC60-0 thru SC60-5, SC2-2, SC2-4, SC Series Special Purpose Tips except SC110 & 110A, SC112 & SC113
MC505	Medium Duty	75°	Oxygen/Acetylene: MC12-00 thru MC12-5
MC509	Medium Duty	90°	Oxygen/Propane, Oxygen/Propane Based: MC40-0 thru MC40-3
CC509P*			Oxygen/Propylene: MC60-1, MC60-2 MC Series Special Purpose Tips

NOTE: DG200 Series supercedes SC200 and SC500 Series cutting assemblies.

DG109A Series supercedes MC509 Series cutting assemblies.

* Supplied in Toughcut™ Outfits - 3 year warranty

